



Pioneering for You

HVAC OEM Competence Centre

Wilo-Para STG ****-*-***/8-75** Datasheet



Wilo-Para STG **-*** /8-75

Heating



Field of application

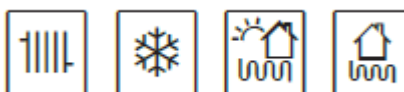

Heating
Cooling
Air-conditioning
Geothermal

Para STG 15-130/8-75

WILO

High Efficiency pump for heating application

STG	Inline cast iron pump housing
15	Threaded connection DN15 (25, 30: also available)
130	Pump housing length 130 (180: also available)
8	8,4= delivery head in [m] at Q = 0 m ³ /h
75	Max power consumption
-	The pump is controlled by Push button technology SC = ΔP-c, constant speed I, II, III or iPWM1/2
12	Control box orientation 12 o'clock (3, 6, 9 o'clock: also available)

Approved fluids
(other fluids on request)

Heating water (in accordance with VDI 2035)
Water-glycol mixtures (max. 1:1; above 20% admixture, the pumping data must be checked)

Power

Energy Efficiency Index (EEI)	≤ 0.21
Max. delivery head	8,4 m
Max. volume flow	4 m³/h

Permitted field of application

Temperature range for applications in HVAC systems at max. ambient temperature. Limit values for continuous operation at maximum rated power	Of 50°C = 0 to 105°C Of 55°C = 0 to 90°C Of 60°C = 0 to 77°C Of 65°C = 0 to 60°C Min fluid temp: -20°C
Maximum static pressure	PN 10

Electrical connection

Mains connection	1~230 V +10%/-15%, 50/60 Hz (IEC 60038 standard voltage)
------------------	--

Motor/electronics

Low voltage directive	2014/95/EC Conform
Electromagnetic compatibility	EN 61800-3
Emitted interference	EN 61000-6-3 EN 61000-6-4
Interference resistance	EN 61000-6-2 EN 61000-6-1
Protection class	IPx4D
Insulation class	F
RoHS / REACH	Compliant but not submitted

Minimum suction head at suction port to avoid cavitation at water pumping temperature

Minimum suction head at 50/95°C	0.5/4.5 m
---------------------------------	-----------

Motor data

Para	Speed	Power consumption 1-230 V	Current at 1-230 V	Motor protection
	n	P1	I	-
	rpm	W	A	-
STG ** /8-75	500 - 4800	10-75	0.03-0.66	Integrated

Materials

Para	Pump housing	Impeller	Pump shaft	Bearing
STG ** /8-75	Cast iron with cataphoresis treatment	PP composite with GF 40%	Stainless steel	Carbon, metal impregnated

Hydraulic operational area



$\Delta p-c$ (constant)

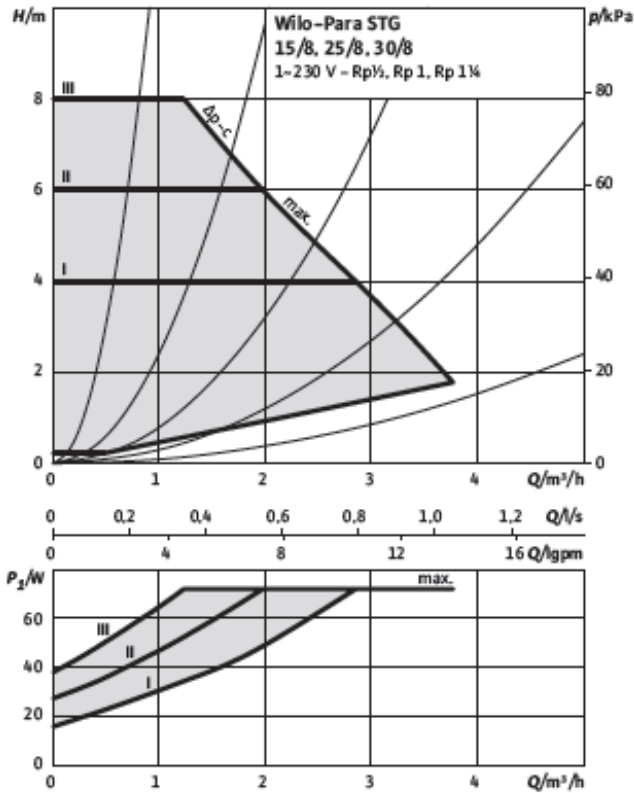

Constant speed I, II, III

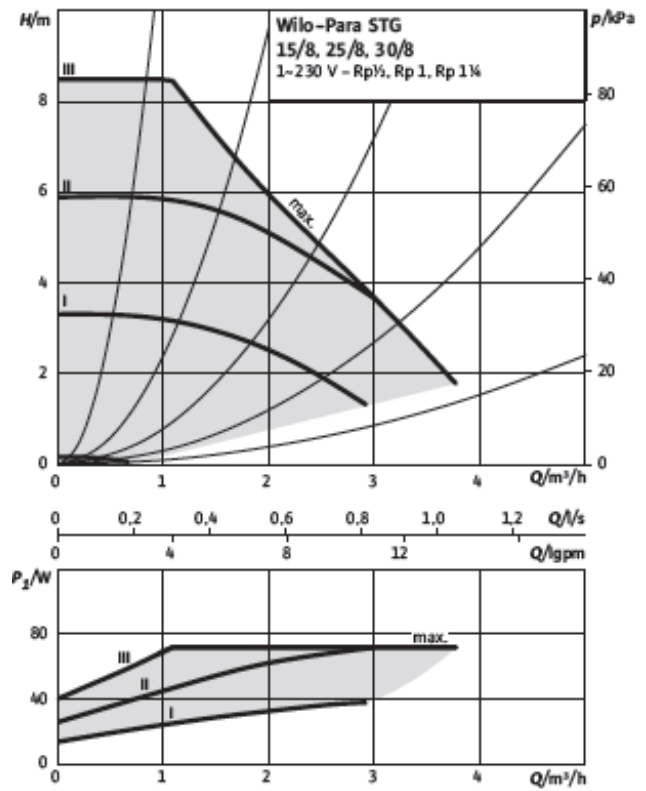

Heating

Datasheet Wilo-Para ** 8/SC 03/07

Hydraulic operational area



Heating



Standard factory setting



Heating

Hydraulic operational area

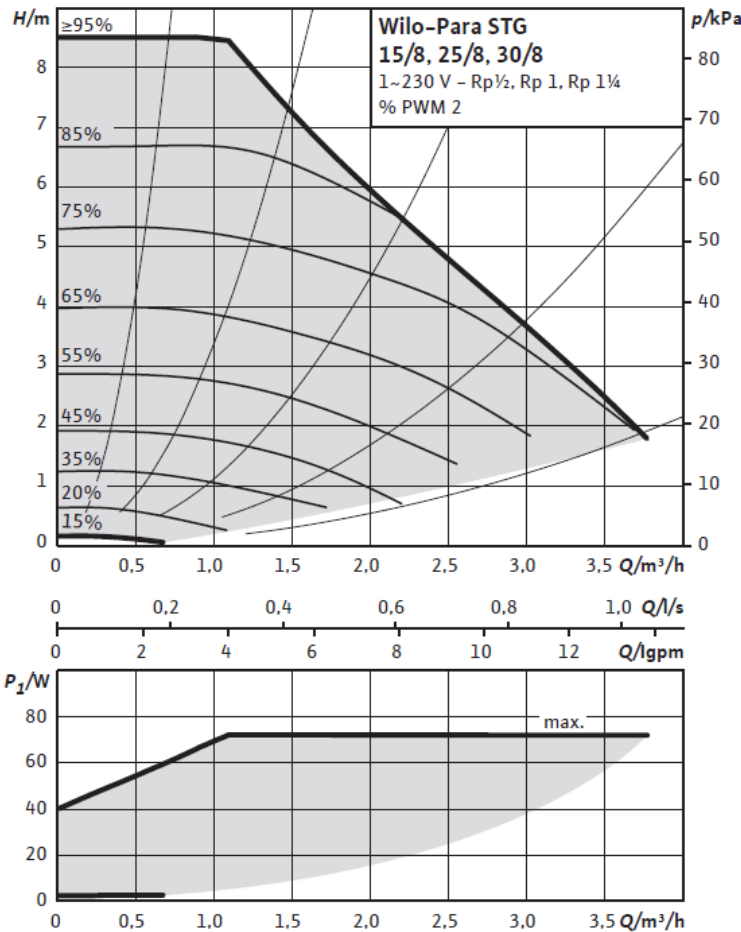
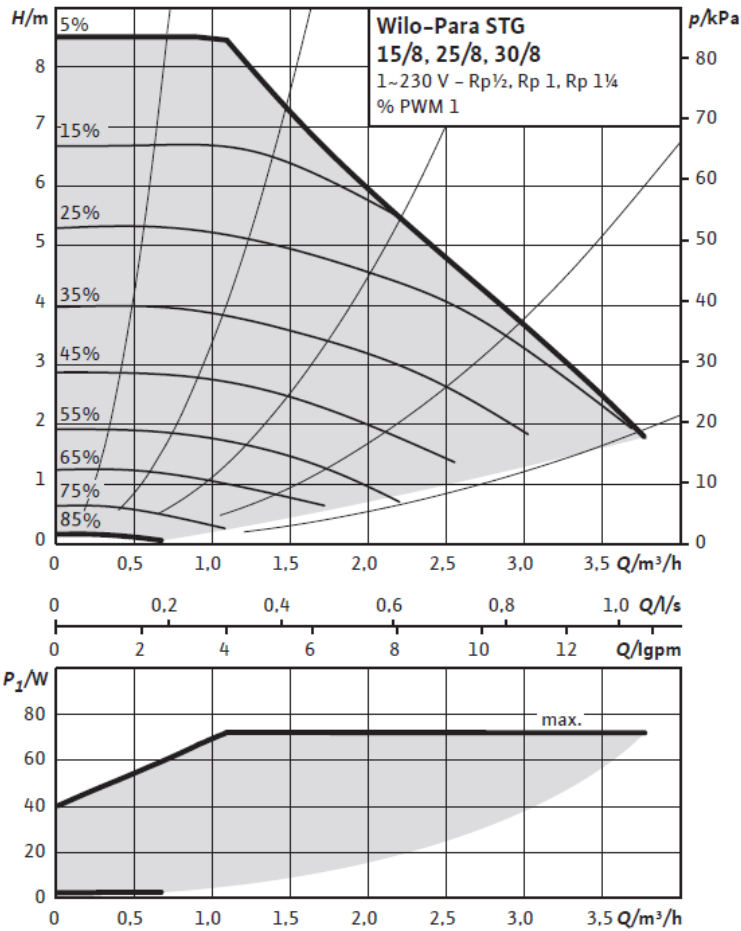



Dimensions

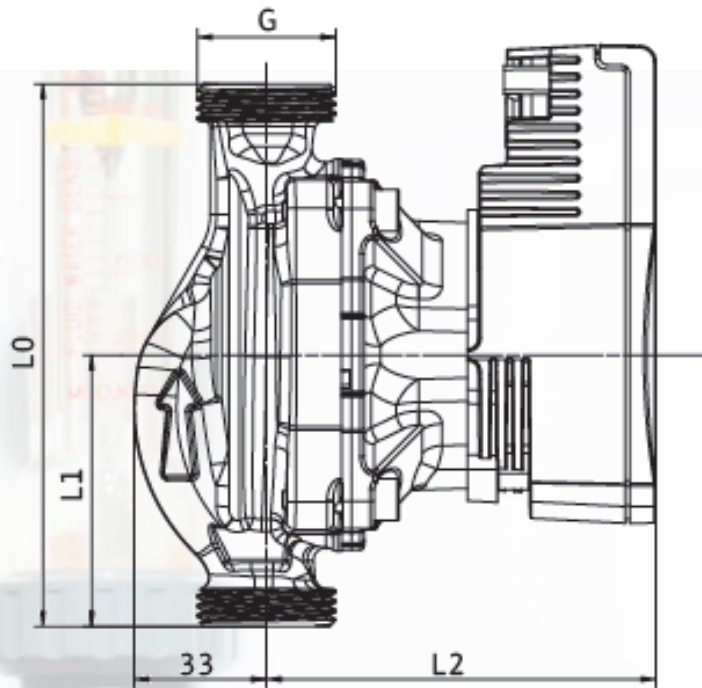
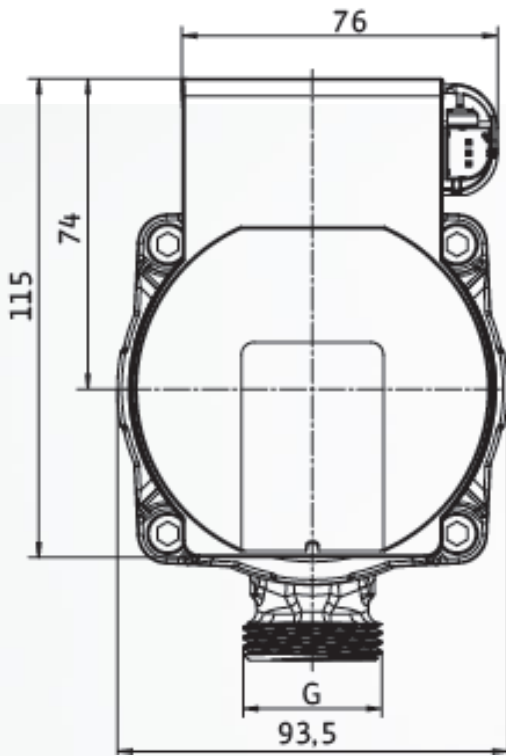

Heating

Technical data				
Designation	Para STG 15-130/8-75	Para STG 25-130/8-75	Para STG 25-180/8-75	Para STG 30-180/8-75
Threaded pipe union	Rp 1/2		Rp 1	
Thread	G 1		G 1 1/2	
Overall length l_0	130 mm		180 mm	
Dimensions L1	65mm		90mm	
Dimensions L2	105mm			
Weight approx. m	1.7 kg	1.8 kg	2 kg	2.1 kg
Materials				
Pump housing	Cast iron with cathaphoresis treatment			
Impeller	PP composite with GF 40%			
Pump shaft	Stainless steel			
Bearing	Carbon, metal impregnated			



Electrical Power connections

Integrated Molex 3-way connector

Heating



Accessories power cable

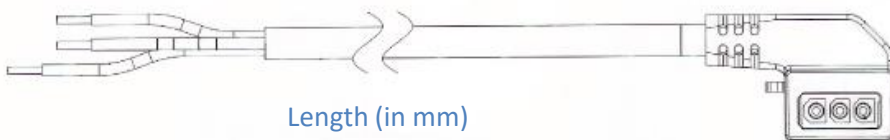

Available mains cables

Overmoulded power connector with brass end splices and type Facon PR260 on terminal box side (disconnection possible)

cable length 500mm	4530966
cable length 1000mm	4524578
cable length 1500mm	4530763
cable length 2000mm	4527857

Not assembled



Molex 3 ways



WS8

Electrical Box orientation

▲ Flow direction

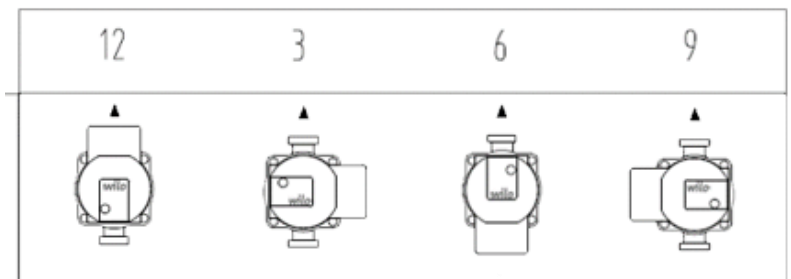



Electrical Signal connections

Front signal connection



Accessories signal cable

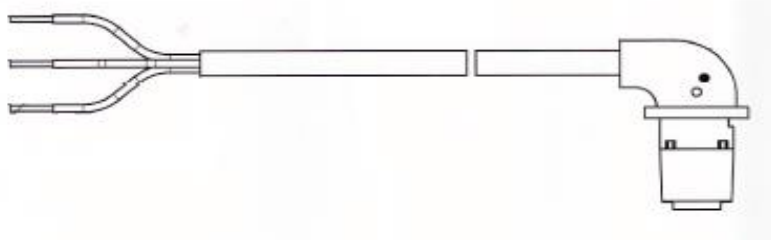

Available mains cables

Overmoulded signal connector with brass end splices and type Facon PR72 (3 wires) on terminal box side (disconnection possible)

Overmoulded signal connector with brass end splices and type Facon PR72 (3 wires) on terminal box side (disconnection possible)	cable length 500mm	4530965
	cable length 1000mm	4530663
	cable length 1500mm	4530764
	cable length 2000mm	4530664

Not assembled



External control via a iPWM system

The actual / setpoint level assessment required for control is referred to a remote controller. The remote controller sends a PWM signal as an actuating variable to the Wilo-Para. The PWM signal generator gives a periodic pulse order to the pump (the duty cycle) according to DIN IEC 60469-1. The actuating variable is determined by the ratio between pulse duration and pulse period. The duty cycle is defined as a ratio without dimension, with a value of 0 ... 1 or 0 ... 100 %. This is explained in the following with ideal pulses which form a rectangular wave.

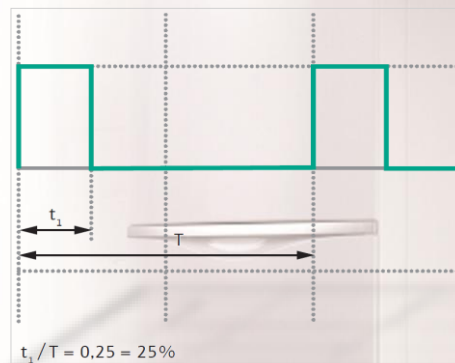
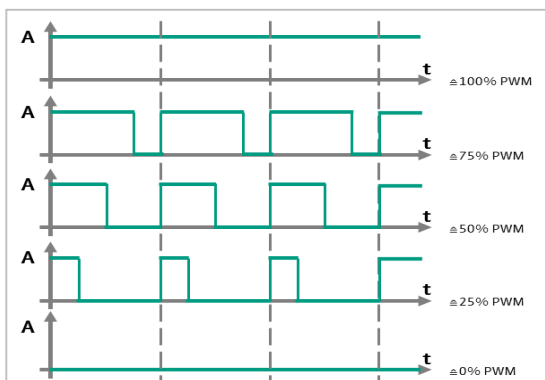

Heating

iPWM interface

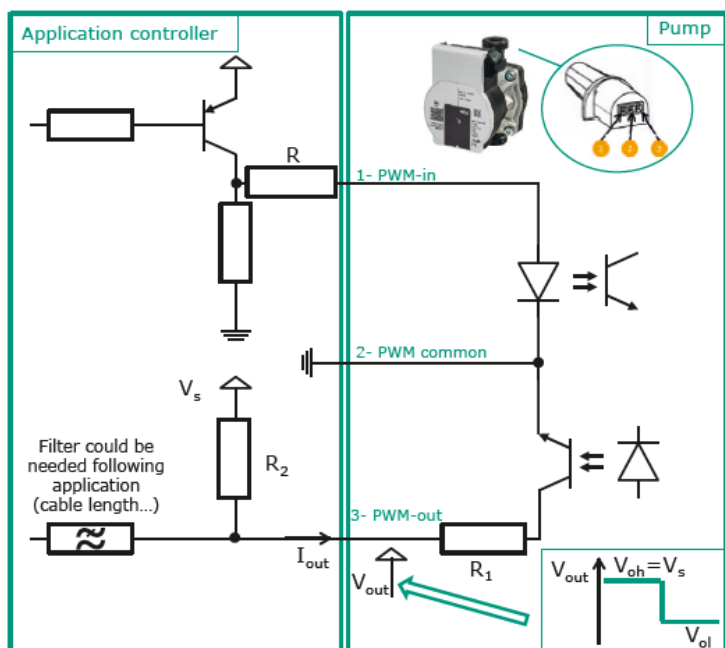

PWM-in	
Signal frequency:	100Hz-5000Hz (1000Hz nominal)
Signal amplitude:	Minimum 3.6 V at 3 mA Up to 24 V for 7.5 mA absorbed by the pump interface
Output resistance [R]:	> 50 Ω (100 Ω nominal).
PWM-in :	> 50 Ω (100 Ω nominal)
PWM-out	
Vs	$3 V \leq V_s \leq 24 V$
R2	$(V_s - 0,2) / I_{out} - R1$
R2C	≤ 1
C=filter capacitor	$1000 \times \ln(0.3) \times 75$ for rise time impact < 0.1 %
Signal frequency:	75 Hz +/- 2 Hz
R1	470 W +/- 5 %
Vol =Vout low	<1V for Iout<1 mA
Signal polarity:	yes



iPWM-in signal logic 1 (heating) (%)

iPWM-in signal logic 2 (Solar) (%)

iPWM signal logic 1 (heating) (%):

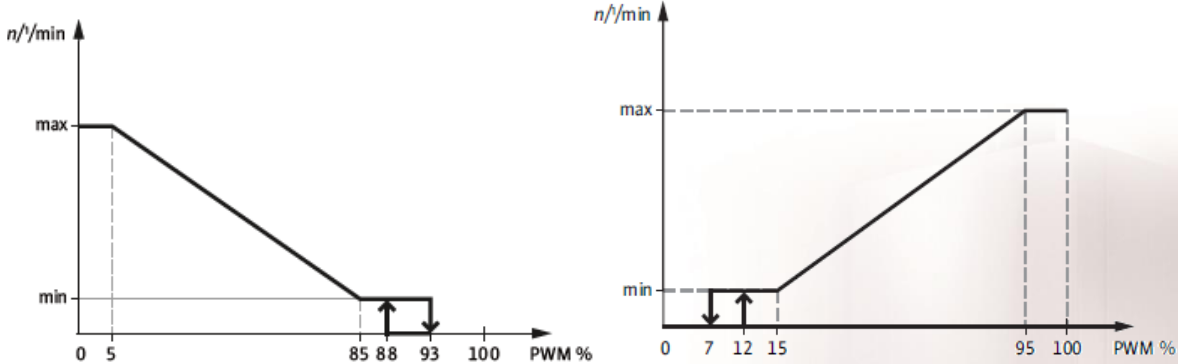

Heating

< 5	Pump runs at maximum speed
5-85	Pump speed decreases linearly from maximum to minimum
85-93	Pump runs at minimum speed (operation)
85-88	Pump runs at minimum speed (start-up)
93-100	Pump stops (Standby)

iPWM-out signal logic (Brine) (%)

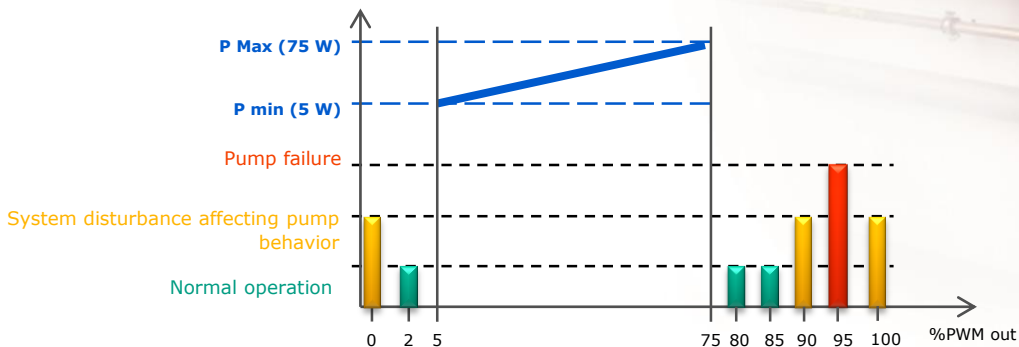

% PWM-out	Status	Potential causes
0	Pump output iPWM interface damaged	iPWM interface in short circuit
2	Stand-by, pump is ready to run	/
5-75	Pump is running normally, flow information is supplied	/
80	Abnormal running mode Pump is running but not at optimal performance	- Undervoltage 160/170-194V - Self thermal protecting mode
85	Abnormal function mode Pump has stopped but is still functional	- Undervoltage <160/170V - Overvoltage - Unexpected external flow
90	Abnormal function mode Pump has stopped but is still functional Check the installation setup and medium	- Failure on another component than pump - Debris in the installation - Bad temperature setup
95	The pump has stopped due to permanent failure	- Pump blocked - Electronic module out of order
100	Problem of iPWM connection	iPWM interface in open circuit

wilo

Pioneering for You

WILO Group – Strategic Business Unit OEM

WILO Intec
50 av. Casella
18700 - Aubigny sur Nère
France
T +33 2 48 81 62 62
information@wilointec.com
www.wilo-oem.com

